

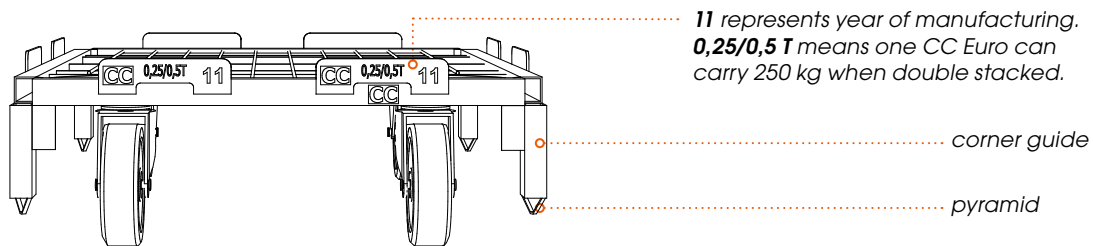

# Instruction functional/non-functional CC Eurocontainer base

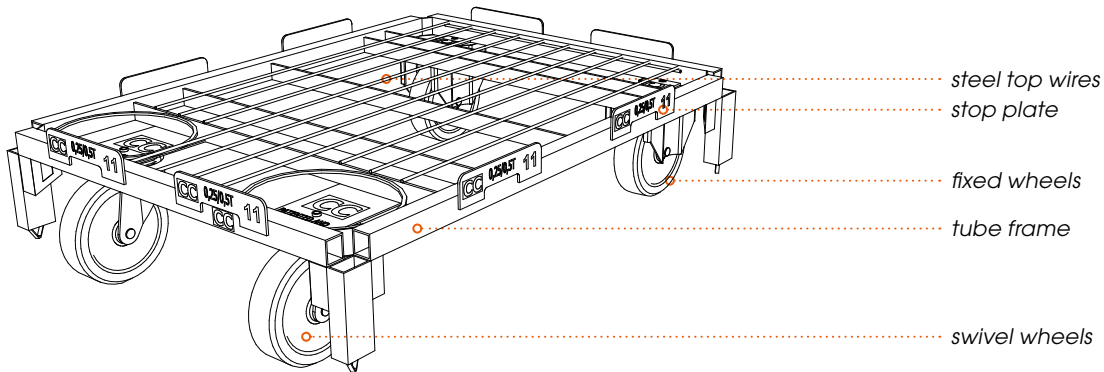

Non-functional bases can be handed in at a CC depot or partner depot for repair and exchanged for functional bases.

## When is a base non-functional?

- 01 The wheel is torn.

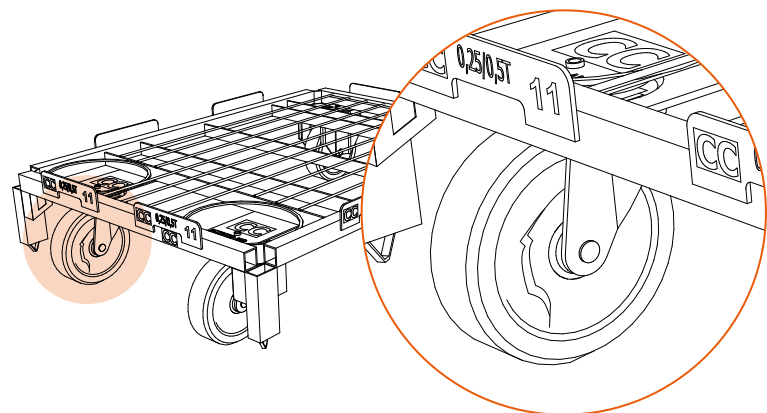



## When is a base non-functional?

(continued)

- 02 Wheel castor has come loose from the base or from the wheel.

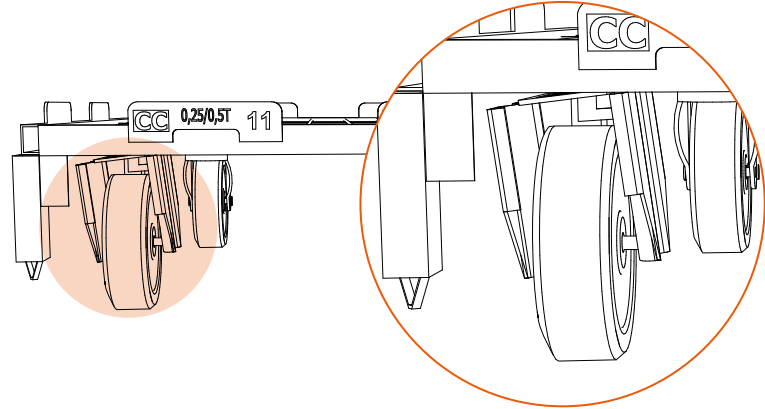

- 03 Wheel is missing or hanging.

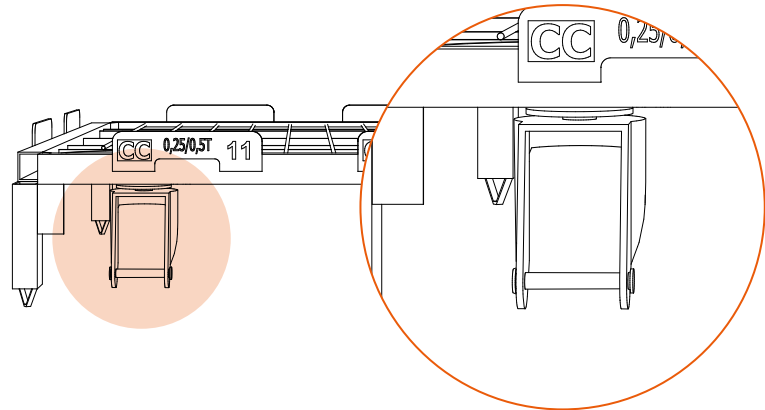

- 04 Wheel cannot turn or the steering wheel cannot turn easily around its axis.

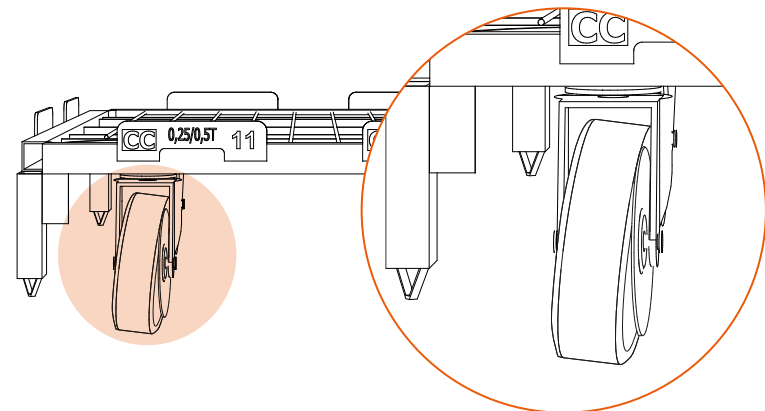

- 05 Corner guides are bent. Stacking according to the stack instructions is not possible.

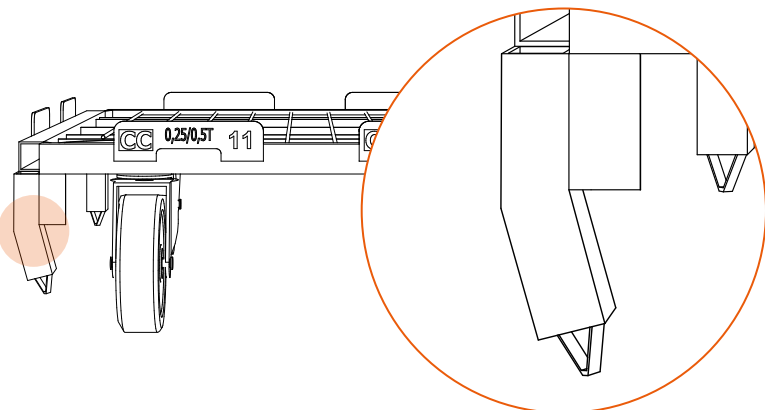



## When is a base non-functional?

(continued)

- 06 Wires are broken.

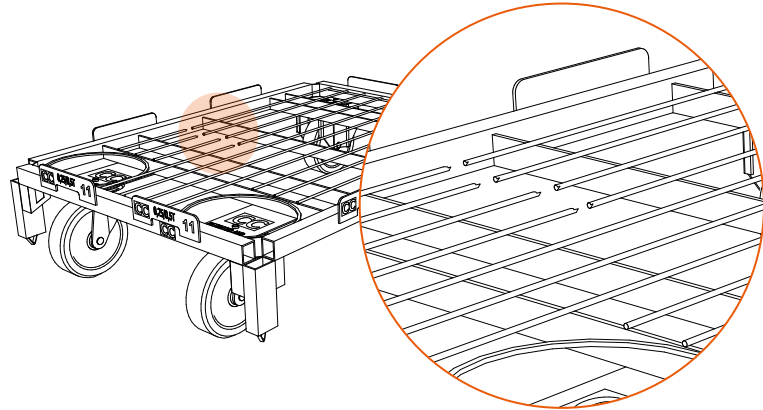

- 07 Tube frame is broken / broke at the welding points.

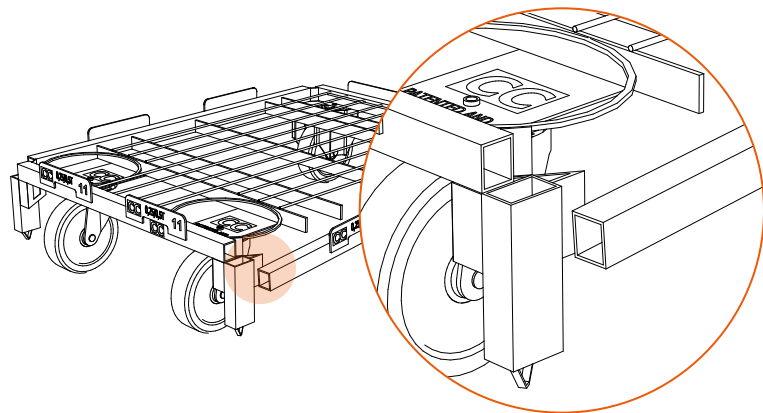

## When is a base not accepted for exchange?

Bases cannot be handed in at a CC depot or partner depot for repair and exchanged for a functional base when:

- The base is functional.  
*Please note:* a base is still considered to be functional when a wheel is wrapped with plastic foil, tape, rope etc.
- The base has no CC marking on the outside or inside.